



SPIDER

**Mounting System for Temperature Sensors in
Temperature and Climatic Chambers**

Model:
Spider-XS
Spider-600
Spider-1000
Spider-Combo

- Secure mounting for up to 11 temperature sensors
 - Adjustable stainless-steel mounting rods
 - Insulated temperature sensor mounts



Applications:

- Temperature and Climatic Chamber mapping
- Chamber validation
- Chamber calibration
- Uniformity studies

Concept:

The Spider facilitates flexible positioning of temperature sensors in climatic chambers. It simplifies the setup of chamber temperature tests, calibration and validation. It features eleven (11) sensor mounts made from flexible and insulating Silicone that isolates the temperature sensor from stainless-steel mounting rods.

The mounting rods are configured so that the user can position the temperature sensors in the top and bottom corners (8), as well as bottom, middle and top of the center line of the chamber. This configuration meets the requirements of climatic testing standards and guidelines such as EURAMET/cg/20, IEC60068, DKD-R 5-7 and NF X 15-140.

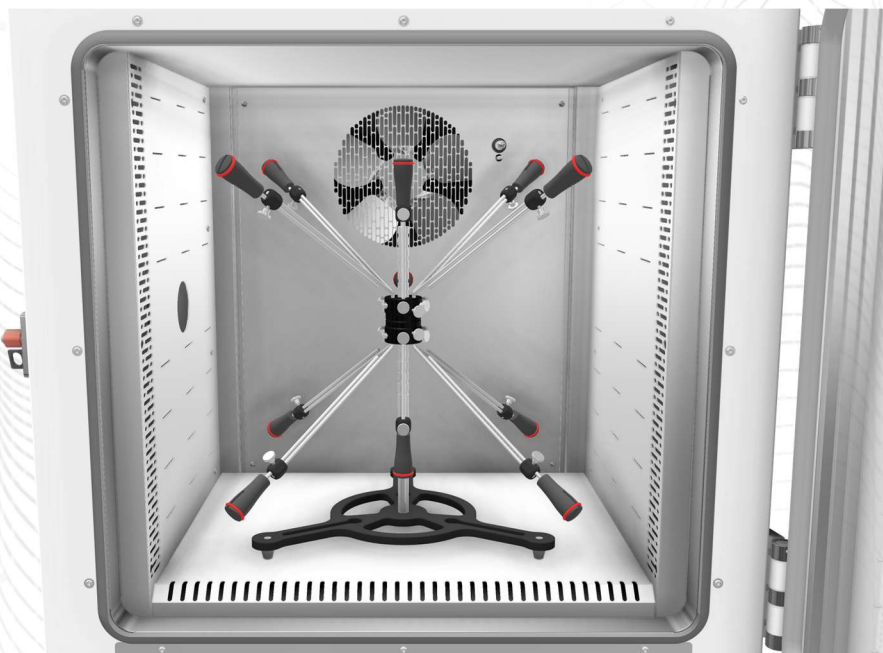

Humidity Uniformity

In combination with a dew point mirror hygrometer, temperature uniformity data can be combined with dew point data for relative humidity uniformity studies. This methodology is defined within the above-mentioned guidelines and standards.

Compatibility

The Spider is suitable for temperature sensors from 3 to 6mm in diameter, and working temperatures from - 100 to + 200 °C. It is suitable for use with any type of multichannel temperature measurement systems.

Spider models and operating volume:

SPIDER XS - max volume

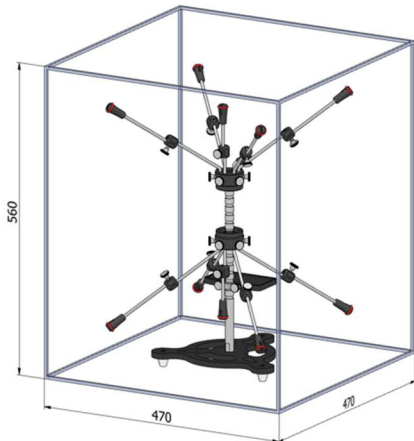

SPIDER XS - min volume

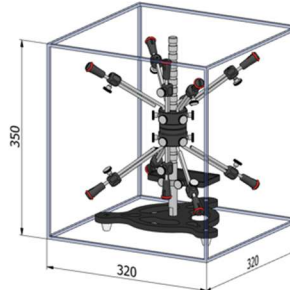

SPIDER 600 - max volume

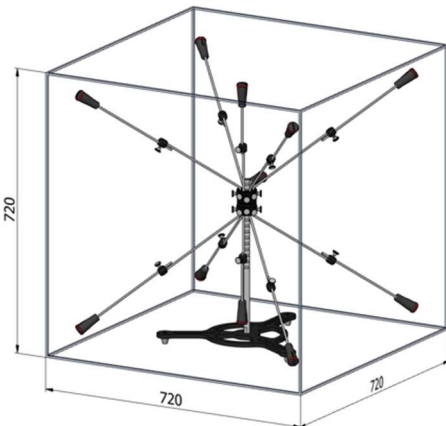

SPIDER 600 - min volume

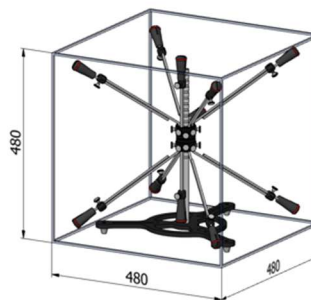

SPIDER 1000 - max volume

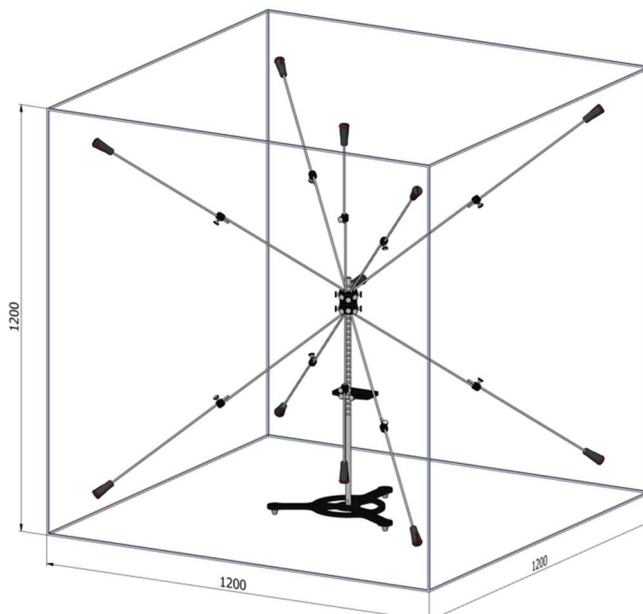

SPIDER 1000 - min volume

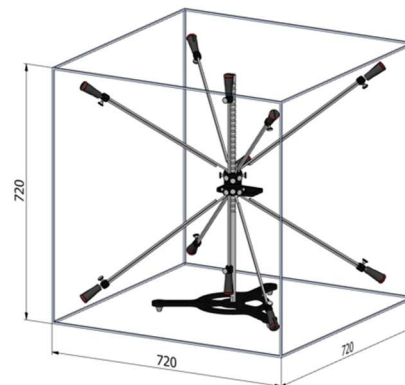

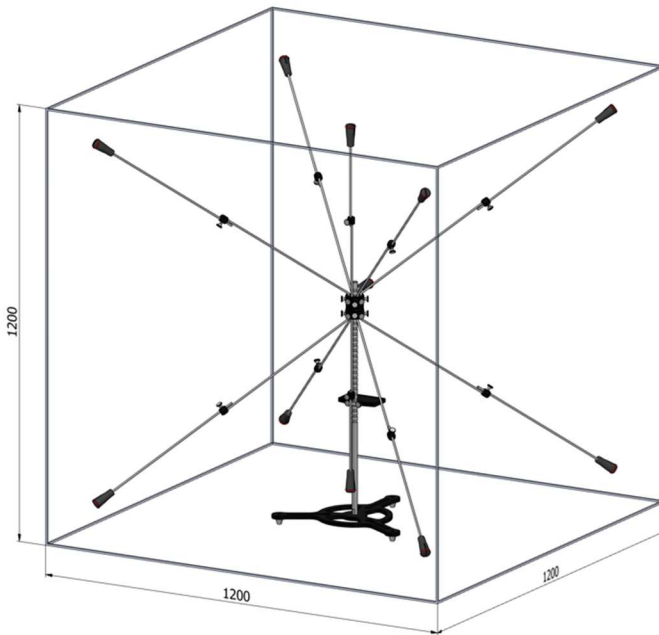

SPIDER COMBO - max volume

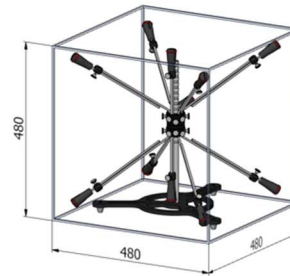

SPIDER COMBO - min volume



Ordering information and accessories:

Description	Part no.
Spider-XS	1045
Spider-600	2824
Spider-1000	2825
Spider-Combo (1 base unit + Spider 600 & 1000 arm holders)	2828
Chilled Mirror dew point hygrometer aluminum shelve	2829
	
Spare silicone end with O-ring 	2830